

borg &  
overström

# Divine

EST 1994

# WATER

Distinctive  
by design.



t1

borg&  
overström

## Advanced performance. Minimalist design.

The T1 is the ideal solution for busy workplaces where space may be at a premium. With advanced dispensing features packaged in a minimal and contemporary design, the T1 will complement even the smallest communal area or kitchenette.



Distinctive  
by design.

t1

# borg & overström

---

## High-capacity dispensing

The T1 eliminates the need for single-use plastic bottles with high-capacity dispensing. It delivers 50 litres per hour of chilled, ambient, and sparkling drinking water, making refilling reusable vessels such as drinking bottles fast and convenient.

---

## Cutting-edge UV protection

As an option, the T1 can be pre-fitted with Viovand<sup>®</sup>, a mercury-free, chemical-free and energy-efficient LED-UV water purification system. For complete peace of mind, it also includes additional hygiene features via Borg & Overström's Totality<sup>®</sup> methodology.

---

## Next-generation ProCore™

Under the counter is a compact powerhouse. ProCore™ is a low-maintenance next-generation water dispensing system. In addition to being energy-efficient, it's fitted with the new eco R290 refrigerant gas.

---

## Plug and play installation

There are no fiddly wires to connect with the T1. The plug and play USB 3 connector makes this tap super easy to install.

---

## Countertop convenience

This integrated tap system can be positioned over a sink or combined with a stylish circular drip tray which complements the design of the tap. The drip tray can either be plumbed into mains waste or used with the Borg & Overström alarmed waste kit.

---

## Minimal yet durable design

Beneath the minimalist, contemporary exterior lies an innovative water dispensing system built for durability and efficiency. The tap is PVD coated for a high-end yet durable finish, while the undercounter cabinet is colour-coated GreenCoat<sup>®</sup> steel.

---

## Low energy consumption

The T1 is consistently energy efficient, making it both economical and eco-friendly. This dynamic integrated tap system is lean and economical, with absolutely no sacrifice to output and quality.

---

## Ventilation kit included

A ventilation kit is included with this system. It's easy to install and increases the efficiency of the ProCore™ by allowing a continuous cycle of cool air.



---

Distinctive  
by design.

t1

# borg& overström

## Water system



Dry Chill®

## Configurations



Integrated Tap

## Water options



Chilled



Ambient



Sparkling

## Tap finishes



Steel



Black



Distinctive  
by design.

## Totality® - Hygiene-assured refreshment



Totality® is our assurance that water dispensed from a Borg & Overström water dispenser is as safe as it is refreshing. Water dispensers with a six-star Totality® rating deliver an exceptionally high standard of hygiene.



### Digital precision

The discreet digital touch panel has an antimicrobial coating for a reassuringly clean experience. Chilled, sparkling, or ambient water can also be dispensed touch-free via the Bluetooth® app.



### Sealed drinking water system.

Dry Chill® is the most hygienic cooling process. No water is stored within the system, which greatly reduces the opportunity for bacteria to become established. Dry Chill® also produces a larger volume of lower temperature water due to its faster recovery time.



### Independently certified anti-microbial, antipathogen sanitising procedure.

All dispensers are sterilised using Sterizen® sanitising infusion. No other brand of watercooler goes through this process, which is why only Borg & Overström appliances are laboratory certified to be 99.999% bacteria reduced.

Distinctive  
by design.

Specifications	T1 ProCore	Dispense options	Max power consumption	Steel	Black	Steel ECO-UV	Black ECO-UV
<b>Tap dimensions</b> W42xD163xH385mm	<b>Power requirements</b> Hertz 50/Volts 230-240	Chilled & Ambient	140W	741010	741000	741030	741020
<b>Dispense height</b> 310mm	<b>Water system</b> Dry Chill®	Chilled & Sparkling	200W	741050	741040	741070	741060
<b>ProCore™ dimensions</b> W320xD375xH335mm	<b>Chilled temperature</b> Min 2°C/Max 11°C	Chilled, Sparkling & Ambient	200W	741090	741080	741110	741100
<b>Simple-fit Ventilation Base</b> W322xD431xH60mm (Includes 20mm overhang)	<b>Throughput flow rate</b> 50 litres per hour (LPH) 60 500ml bottles per hour (BPH)						

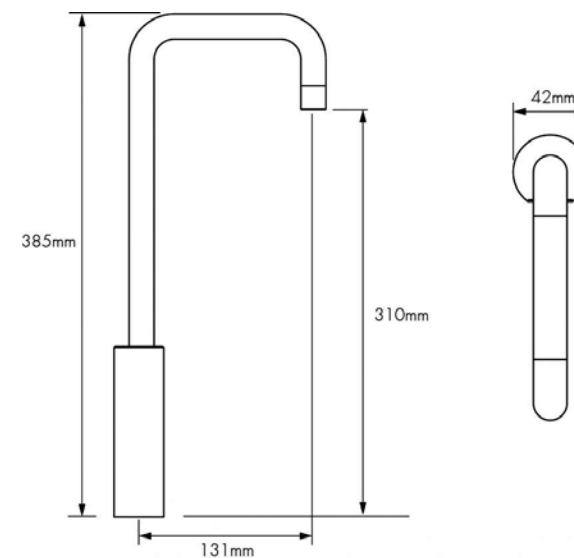
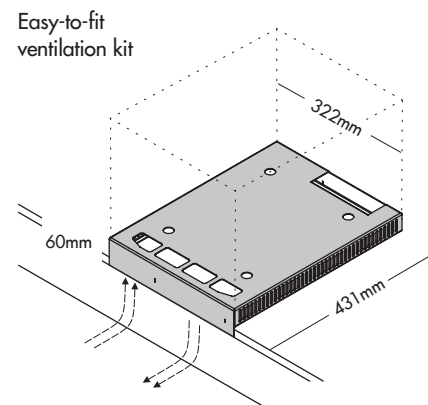

Distinctive  
by design.



# Divine WATER

EST 1994

Talk to an adviser:

01892 669609

[sales@divinewater.co.uk](mailto:sales@divinewater.co.uk)

[www.divinewater.co.uk](http://www.divinewater.co.uk)